

✓
200900077210
Filed for Record in
HENRY COUNTY OHIO
SARA L MYLES
11-03-2009 At 01:57 pm.
EASEMENT 44.00
OR Volume 247 Page 1543 - 1546

AUDITORS OFFICE
NOT TRANSFERRED
NOV 03 2009
Kevin J. Myles
HENRY CO. AUDITOR

200900077210
CITY OF NAPOLEON
PICK-UP

PERPETUAL EASEMENT

KNOW ALL MEN BY THESE PRESENTS: That, Roger A. Robinson and Beverly A. Robinson, husband and wife, "Grantors", whose tax mailing is 933 W. Graceway, Napoleon, Ohio, 43545, for and in consideration of the sum of one dollar (\$1.00) and other good and valuable consideration paid by the CITY OF NAPOLEON, OHIO, a municipal corporation organized under the laws of Ohio, the Grantee, the receipt and sufficiency of which is hereby acknowledged, does hereby **GRANT, BARGAIN, SELL, CONVEY AND RELEASE** to the Grantee, its successors and assigns forever, a perpetual alienable utility Easement to lay, install, construct, reconstruct, erect, use, repair, supplement, maintain, operate, and/or remove, at any time or times hereafter, its Storm Sewer (drainage), being considered for the purpose of this easement, a "Utility". The aforementioned Utility for the purpose of this Easement consist of one or more pipes, metering equipment, and appurtenances, all the aforementioned being above and below ground with extensions therefrom, in, on, through, over and/or under the below described lands, with the right of ingress to and egress from and over said premises (real estate) situated in the County of Henry and State of Ohio, and described as:

**SEE ATTACHED EXHIBIT "A", INCORPORATED HERETO.
SEE EXHIBIT "B" FOR ILLUSTRATION PURPOSES ONLY**

SUBJECT TO ALL LEGAL HIGHWAYS, EASEMENTS, ZONING REGULATIONS, AND RESTRICTIONS OF RECORD.

The Grantors claims title to the above described property by virtue of a deed record recorded in Official Records **VOLUME 211 AT PAGE 976** of the records of Henry County, Ohio.

Grantee will also have the right to mark the location of the strip by suitable markers set in the ground, but such markers when set in the ground will be placed in locations which will not unreasonably interfere with any reasonable use the Grantors will make of the land.

The consideration recited herein shall constitute full and final payment for said easement and all damages sustained and/or claimed by the Grantors, their executors, administrators, successors, and assigns, including but not limited to all damages to the remainder of the Grantor's real estate, that arise from or by reason of the laying, installation, construction, reconstruction, erection, use, operation, maintenance, supplementation, removal or inspection of said Utility and all appurtenances thereto, including but not limited to those known or unknown, those legal, equitable or otherwise and those direct, incidental or consequential. Nevertheless, Grantee agrees to restore the grounds by seeding and leveling. The Easement and right-of-way hereby granted includes the perpetual right to cut, trim, and/or

otherwise control any trees and/or brush which may endanger the safety of or interfere with the construction and use of said Utility(s) without claim of damage to the trees or brush by the Grantors.

TO HAVE AND TO HOLD said Easement, together with all rights and privileges belonging thereto unto the Grantee and its successors and assigns forever. This Easement together with all agreements, covenants, and other provisions recited herein, shall constitute a covenant running with the land for the benefit and use of the Grantee, its successors and assigns forever.

The Grantors hereby covenant that they are the true and lawful Owners of the above described real estate and has full power and authority to convey the same; that the same is free and clear from all liens and encumbrances whatsoever and that the Grantors will warrant and defend the title to the said easement against all lawful claims.

EXECUTED BY: Roger A. Robinson and Beverly A. Robinson, Grantors, this 19th day of October, 2009.

Roger A. Robinson
Roger A. Robinson

Beverly A. Robinson
Beverly A. Robinson

STATE OF OHIO }
 }
COUNTY OF HENRY }

ss:

Before me a Notary Public in and for said County, personally appeared the above named, Roger A. Robinson and Beverly A. Robinson, the Grantors, who acknowledged they did sign the foregoing instrument and that the same is their free act and deed.

IN TESTIMONY WHEREOF, I have hereunto set my hand and seal this 19th day of October, 2009.

(Seal)



SHERYL K. RATHGE
Notary Public, State of Ohio
Henry County
Commission Expires October 15, 2011

Sheryl K. Rathge
Notary Public

ACCEPTED BY:

Jon A. Bisher
Jon A. Bisher, City Manager

20 OCT 09
Date

THIS INSTRUMENT PREPARED AND APPROVED BY:

David M. Grahn
City of Napoleon Law Director
255 West Riverview Avenue
Napoleon, Ohio 43545
(419) 592-3503

EASEMENT DESCRIPTION PREPARED BY:

Feller Finch & Associates, Inc.
P.O. Box 68, Maumee, Ohio 43537-0068

LEGAL DESCRIPTION VERIFIED BY:

Chad Lulfs P.S. P.E., Napoleon Engineer

Exhibit "A"

April 28, 2009

10' Wide Permanent Drainage Easement
Roger A. Robinson and Beverly A. Robinson
933 W. Graceway

Being a parcel of land in the City of Napoleon, Henry County, Ohio, being bounded and described as follows:

The West ten (10.00) feet of a parcel of land as recorded in Volume 211, Page 976, Henry County Deed Records, subject to any and all leases, easements and restrictions of record. Being the same as shown on the plans for Contract No. 2008-36, West and East Graceway Drive Sewer Improvements, prepared by Feller, Finch & Associates, Inc., on file with the City of Napoleon.

Said parcel of land recorded in Volume 211, Page 976, Henry County Deed Records being described as follows:

The North thirty-two (32.00) feet of lot number twenty-two (22) and lot number twenty-three (23) except the North forty-nine (49.00) feet thereof, in Richter's Third Addition to the City of Napoleon, Henry County, Ohio.

Prepared by:

FELLER, FINCH & ASSOCIATES, INC.



D. Edward Thornton, P. S.
Professional Surveyor No. 7827

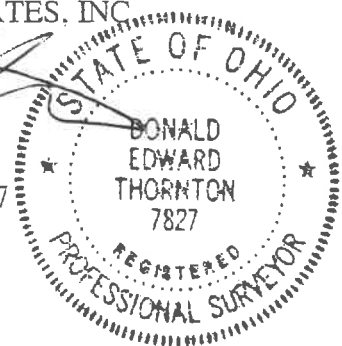

P:\Projects\10E06292\Wordprocessing\Legal\10E06292\g-Robinson 10' Wide Permanent Drainage Easement.DOC

**Feller,
Finch**
& Associates, Inc.
Engineers • Surveyors

1683 Woodlands Drive • P.O. Box 68 • Maumee, Ohio 43537-0068

Additional office in Jackson, Michigan (419) 893-3680
Fax (419) 893-2982
www.fellerfinch.com

10' WIDE PERMANENT DRAINAGE EASEMENT EXHIBIT
933 W. GRACEWAY
PART OF THE NORTH 32.0' OF LOT 22 AND LOT
23, EXCEPTING THE NORTH 49.0' THERE OF, IN
RICHTER'S THIRD ADDITION
CITY OF NAPOLEON, HENRY COUNTY, OHIO

ROGER A. ROBINSON &
BEVERLY A. ROBINSON
OFFICIAL RECORD 211, PAGE 976
HENRY COUNTY, DEED RECORDS

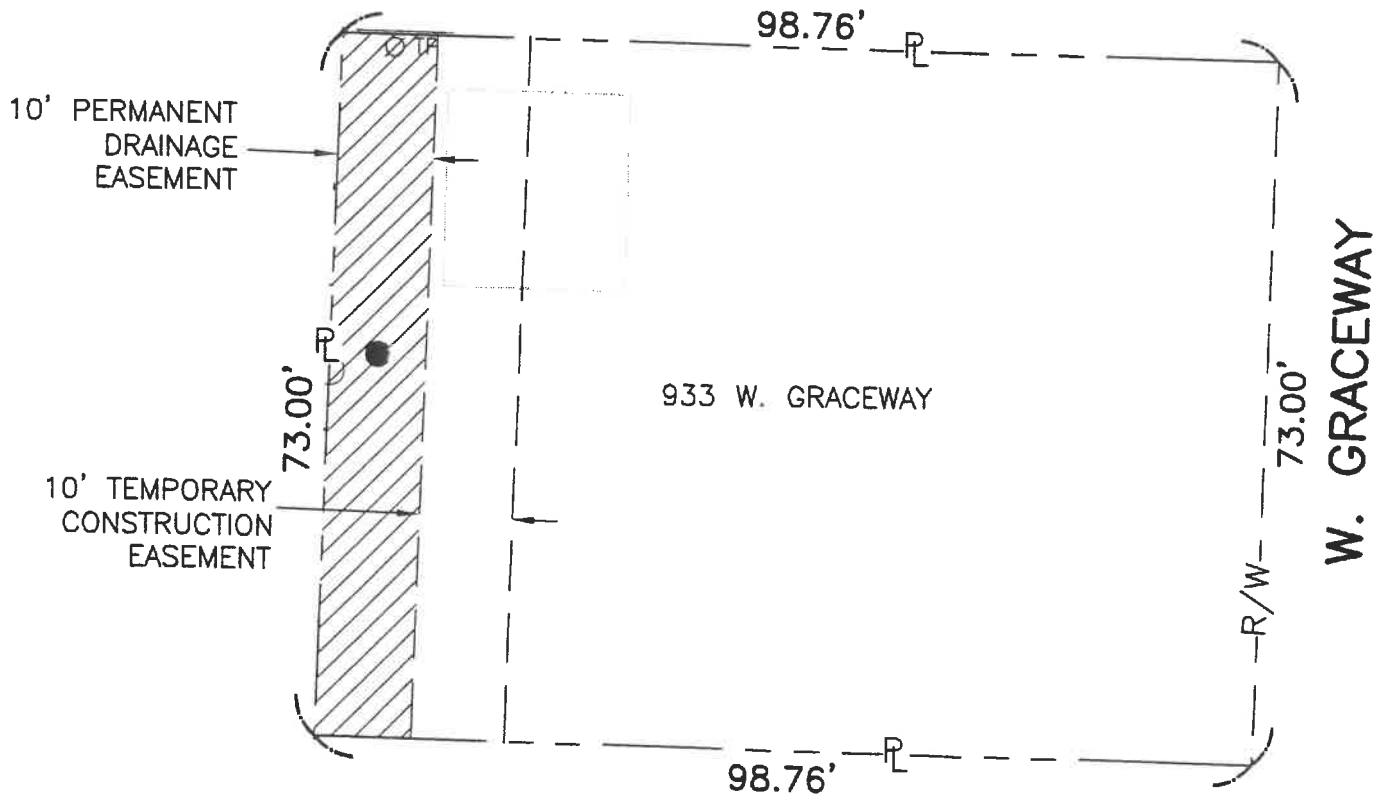

P:\Projects\10E06292\dwg\10-06292FE00A1.dwg, 7, 5/4/2009 11:11:29 AM, dmccall

© 2009 FELLER, FINCH & ASSOC., INC.

SCALE:	1"=20'
DATE:	4-29-09
DRAWN BY:	RGS
PROJECT NO.:	10E06292
DRAWING:	10-06292FE00A1



**Feller
Finch**
& Associates, Inc.
Engineers · Surveyors
Landscape Architects · Planners

1683 Woodlands Drive · P.O. Box 68 · Maumee, Ohio 43537

Phone: (419) 893-3680

Fax: (419) 893-2982

www.fellerfinch.com